

SIEMENS

Ingenuity for life

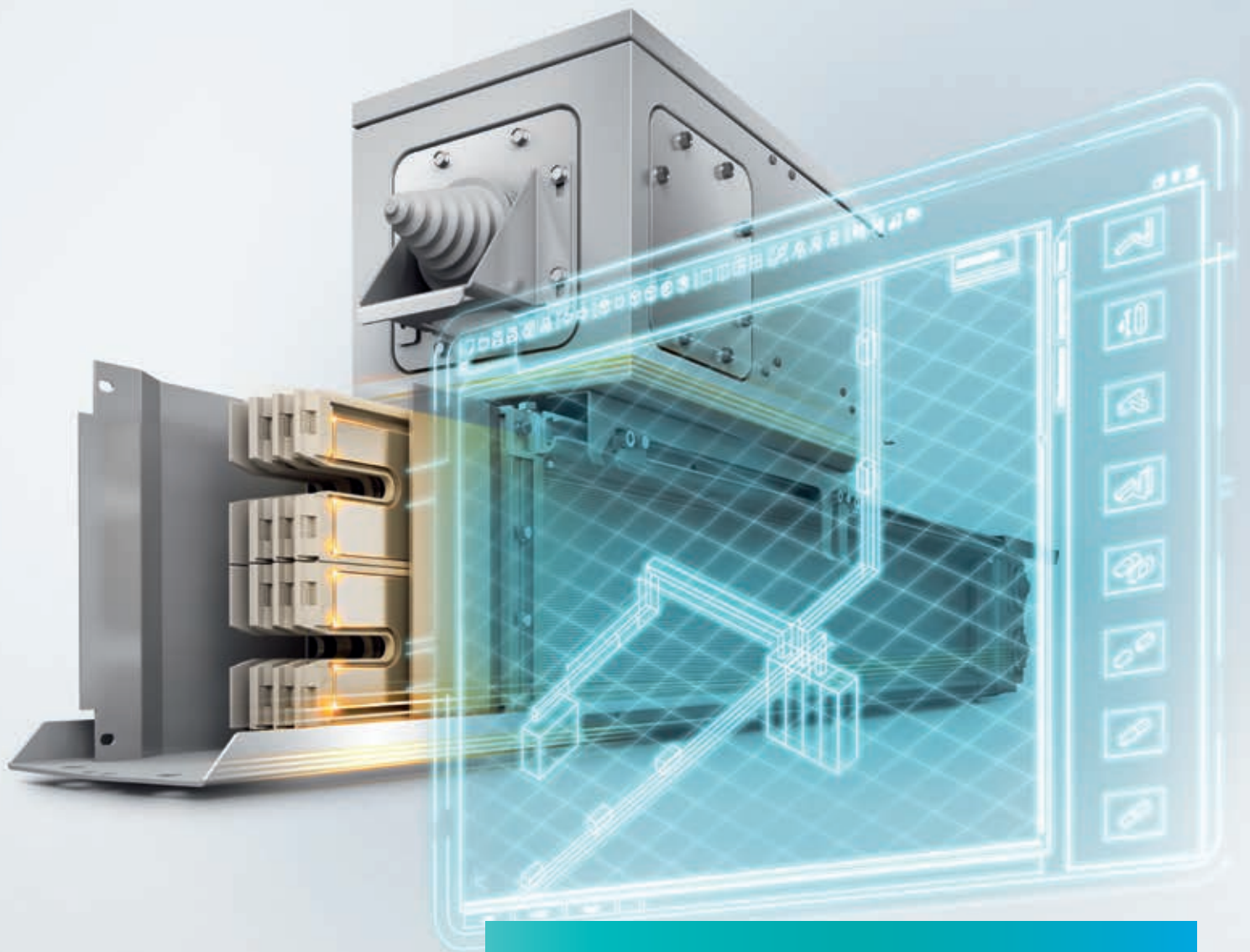

An integrated solution
for safe and efficient
power supply

Totally Integrated Power – SIVACON 8PS
LI busbar trunking system

[siemens.com/LI-system](https://www.siemens.com/LI-system)

Contents

Totally Integrated Power	2
SIVACON 8PS busbar trunking system – LI system	3
Applications of the LI system	4
Benefits of the LI system	6
SIVACON 8PS – LI system	12
Body sizes	13
Conductor configuration	14
Power transmission	15
Power distribution	17
Hook and bolt connections	20
Technical data	21
Support	23

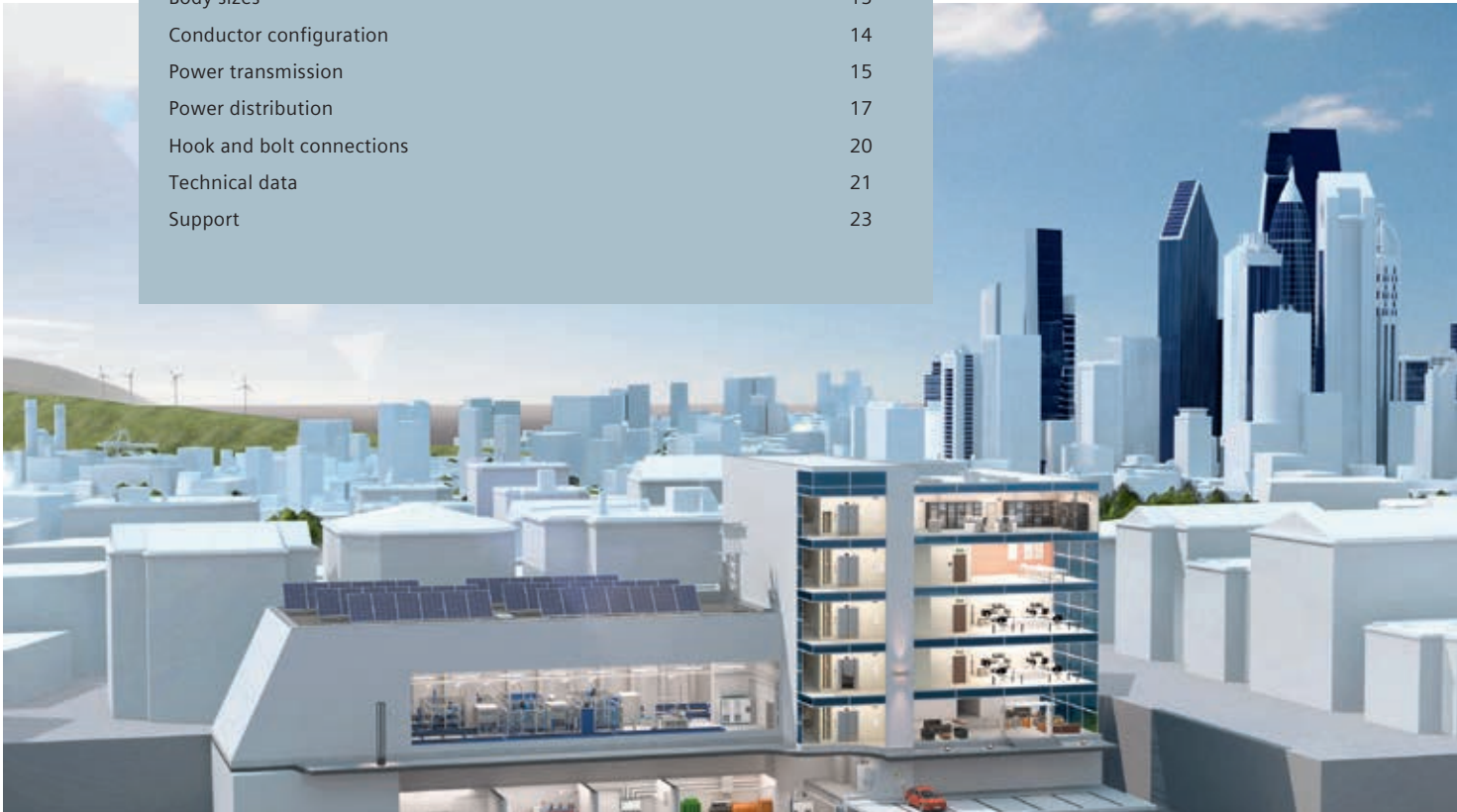

Totally Integrated Power

The importance of electrical power as an energy source for industries, buildings, and infrastructures is increasing steadily. Each business has specific needs and challenges and requires a versatile, adaptable, and tailored power supply in order to optimize availability and profitability. Totally Integrated Power (TIP) from Siemens is a completely customizable and integrated power supply solution comprising software and hardware products, systems, and solutions across all voltage levels. TIP perfectly integrates into industrial and building automation systems and enables companies to focus on their core business while supporting their value chains using a reliable, safe, and efficient power supply. Because power matters.

The LI busbar trunking system from the SIVACON 8PS product range is an integral part of Totally Integrated Power. Power is delivered safely and reliably to the loads – and in a flexible and efficient way.

In infrastructure and industrial applications, the LI system provides an integrated solution to all application requirements of power transmission and power distribution from 800 A to 6300 A.

SIVACON 8PS busbar trunking system – LI system

An integrated solution for safe and efficient power supply



Your benefit

Business understanding

- Compact design
- Modular tap-off units
- Integration in energy management solutions in accordance with ISO 50001

System and operational safety

- Design verified switchgear and controlgear assembly in accordance with IEC 61439-1/-6
- High degree of protection IP55, IP66¹⁾
- Fire barriers in accordance with European Standard EN 1366-3

Reliability

- High short-circuit rating
- Full load at high ambient temperature
- Hook and bolt connection

Innovation

- Modern power distribution by means of busbar trunking system

One-stop shop

- From planning via installation to operation

Safe solution

The LI system offers a broad range of design verified trunking and tap-off units in accordance with the IEC 61439-1/-6 standards, enabling a high level of personnel and system safety as well as improved operational availability. The high degrees of protection IP55 and IP66 for power distribution or power transmission contribute to this.

The fire barrier for the LI system has been tested for fire resistance classes EI90 and EI120 (category of EN 13501) in accordance with EN 1366-3 to meet building requirements according to European Standards, providing a high level of safety for your infrastructure.

Efficient solution

Today's infrastructures require space-saving power supply. The compact design of the LI system satisfies this requirement and facilitates integration into all buildings in order to achieve a cost-efficient infrastructure. Innovative technical features, such as tap-off units with measuring devices, enable a modern energy management in accordance with ISO 50001 – meeting the latest demands for increased power efficiency. The LI system offers high flexibility and security of investment for the design of integrated power supply solutions.

1) IP66 for power transmission

Applications of the LI system

Supplying large amounts of power
over long distances for infrastructure
and industry

Modern infrastructure and industry depend on a supply of electrical energy that is safe, flexible, reliable, and efficient. The LI system is the right solution to these requirements. For example, a high degree of protection, a high short-circuit rating, and low voltage drop ensure optimum operational reliability combined with maximum personnel safety and efficient operation.

The flexibility of its tap-off units and a compact design support efficient planning and installation as well as a cost-effective infrastructure. Furthermore, as part of the SIVACON 8PS and TIP portfolio, the LI system contributes to integrated and future-proof solutions.

High-rise structures



Typical demands

- Low fire load
- Low space requirements
- Flexibility of tap-off units

High-rise buildings need a flexible and reliable power supply in the smallest possible space. Demands vary depending on how the building is used, but safety is always the top priority, and functional endurance in case of fire is a key consideration. In case of fire, the LI system helps safeguard life and infrastructure due to low fire loads as well as fire barriers in accordance with European Standards (tested according to EN 1366-3 and classified according to EN 13501-2).



Data centers



Typical demands

- Standby power system
- Redundant power supply to the loads
- 200 % N to avoid overloads on the neutral caused by the huge amount of electronic and single-phase loads
- Clean Earth requirement with separate PE conductor insulated to the busbar trunking system housing

Data centers require maximum reliability of supply and transparency in power distribution, and generally have a very large power density. Built-in redundancy is essential for data centers so as to ensure perfect reliability. A high amount of electronic and single-phase loads must not overload the neutral conductor.

The LI system interconnects the UPS system and the transformers with the main distribution board. With an N conductor of 200 %, potential demands for increasing the cross-section of the neutral conductor can also be met.

Tap-off units record the power consumption and transfer the data required to the control room via a separate bus system.

Infrastructure



Typical demands

- Compact design to meet the low space requirements
- Standby power system
- Redundant power supply to the loads
- Fire barriers in accordance with state-of-the-art safety standards
- Complete, design verified solution including connection between switchboard and busbar trunking system
- Integrated solutions for modern energy management in accordance with European Standards

Critical infrastructures such as airports have diverse power system requirements. The most reliable power supply possible with the lowest fire load level is required in all areas, and space must be optimally used.

The LI system supports an integrated solution for an efficient infrastructure. Tap-off units can be equipped with communication-capable measuring devices that enable modern energy management. The compact design of the system allows cost-efficient buildings. Furthermore, features such as fire barriers enable to meet European building requirements for infrastructure.

Manufacturing industries



Typical demands

- Concept flexibility
- Flexible tap-offs for loads
- Reliable supply and high availability
- High degree of protection
- Tap-off units up to 1250 A
- TN-S grid

Manufacturing industries such as solar and microchip require large amounts of power and therefore have their own medium-voltage transformers. Power supply must be flexible to adapt to changes in the use of manufacturing areas and the introduction of new machines with different performance demands. The high power density for electrical power supply requires large rated currents for tap-off units, which can be plugged on/off the energised¹⁾ runs up to 1250 A.

The LI system provides a safe connection between the transformer and the main distribution board. Energy can be efficiently managed with communication-capable measuring devices and tap-off units with interfaces for communication via PROFIBUS, Modbus, or PROFINET. Power supply is additionally both safe – with a high degree of protection, high short-circuit rating, and low fire loads – and flexible due to modular, plug-on/off tap-off units.

1) In accordance with EN 50110-1 (VDE 0105-1); please always observe national regulations/standards

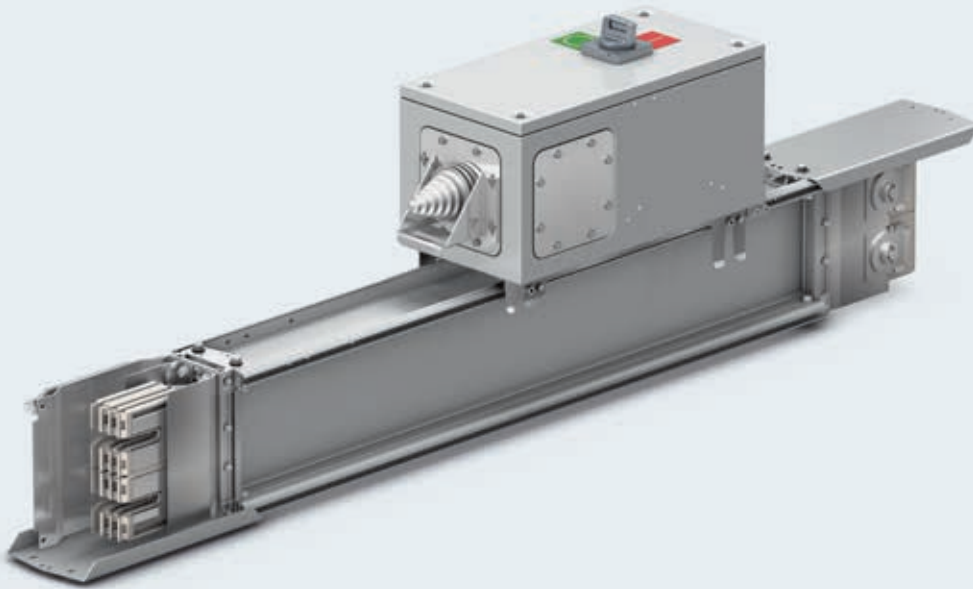

Benefits of the LI system

Proven technology combined with future-proof functionalities

The LI system is a future-proof investment due to its flexibility in load change and integration into energy management systems. A reliable and flexible system that is safe for personnel and equipment, and highly efficient from planning via installation to operation.

Integrated

and future-proof
for investments

Safe

for personnel
and equipment

Efficient

in all
project phases

Flexible

in planning
and operation

Reliable

for high
availability

Integrated and future-proof.

Invest in an efficient power supply solution

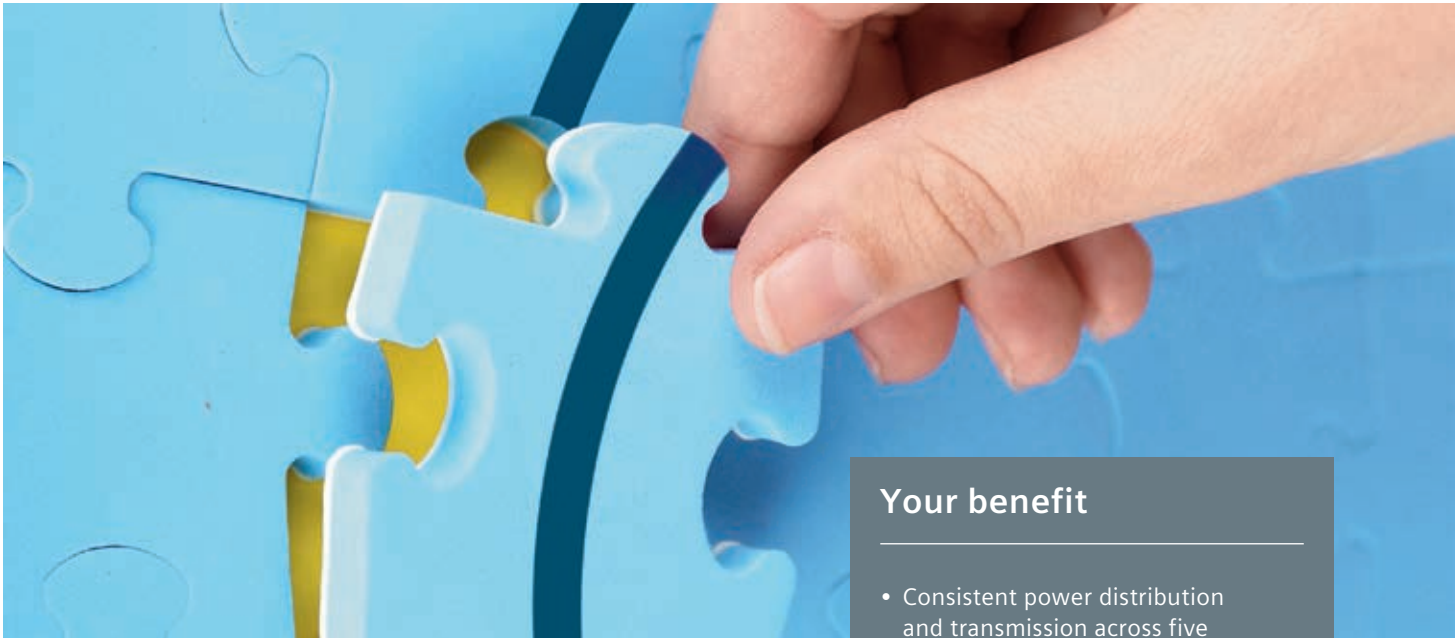

The LI system is part of an integrated product and system portfolio for power supply. A consistent and safe power supply is possible through design verified connections to SIVACON S8 switchboards, and safe connections to transformers as well as to the four other SIVACON 8PS busbar trunking systems.

It enables future-proof integration into a company energy management system in accordance with ISO 50001 by using built-in communication-capable switching and measuring devices.

The result: improved efficiency for industrial and infrastructure applications.

Your benefit

- Consistent power distribution and transmission across five SIVACON 8PS busbar trunking systems
- Design verified connection to SIVACON S8 switchboards
- Communication-capable switching and measuring devices for energy management
- Communication-capable switching devices for remote switching and monitoring

Safe for personnel and equipment.

Safeguard your investment

The LI system delivers safety for your staff and for your infrastructure. The design verified LI system in accordance with IEC 61439-1/-6, as well as its design verified connection to SIVACON S8 switchboards ensure optimum personnel and system protection, offering a high level of reliability.

Features such as low fire loads, light and rugged aluminium housing, high degree of protection, and high short-circuit rating help safeguard human life and your investment.

A plug-on/-off facility enables guided installation and removal of the tap-off units with unambiguous indication of the disconnected position.

To meet structural requirements for preventive fire protection measures, the LI system can also be fitted with fire barriers EI90 and EI120 (category of EN 13501), tested in accordance with EN 1366-3, to comprehensively fulfil European building regulations.

Your benefit

- Design verified in accordance with current standard IEC 61439-1/-6
- Design verified connection to SIVACON S8 switchboards in accordance with IEC 61439-1/-2
- Guided installation and removal of the tap-off units with disconnected position
- High degree of protection IP55 for power distribution with tap-off units, and IP66 at every hook and bolt connection
- High short-circuit rating to enable safe operation even during faulty conditions
- Low fire loads to reduce damages in the case of fire
- Fire barriers tested in accordance with European Standard EN 1366-3
- Fire resistance of 180 min in accordance with IEC 60331
- Low weight and high rigidity with aluminium housing





Your benefit

- Support in all project phases from experts at Totally Integrated Power (TIP)
- SIMARIS planning tools and online support
- Compact design for optimised run and assembly
- Decentralised power distribution for high transparency
- Fixing accessories to easily fit a range of building structures

Efficient in all project phases.

Optimise your time with Siemens as a competent project partner

Innovative SIMARIS planning tools support your planning process effectively at every stage.

- SIMARIS design for network calculation and dimensioning
- SIMARIS project for determining the space requirements of the power distribution system, calculating the budget, and creating technical specifications
- SIMARIS sketch for simple 3D routing and visualisation of busbar runs

As a planner, you can benefit from professional consulting, software tools, specification texts, and planning manuals provided by our experts at Totally Integrated Power (TIP).

The LI system itself contributes to an efficient planning and installation by offering a compact design as well as integrated components such as modular tap-off units, junction units, transformer feeding units, and SIVACON S8 connections.

Installers also have the choice between various fixing accessories for easy mounting of horizontal or vertical runs.

As the tap-off units are located close to the consumers and loads, the decentralised power distribution furthermore enables cost-efficient operation.

Your benefit

- Variety of feeding units and accessories to connect to transformers, switchboards, and other power sources
- Range of conductor configurations to fit grid types
- Compact design for high current ratings as double body side-by-side for vertical and horizontal runs
- Quick and easy modification or expansion with plug-on/-off tap-off units (up to 1250 A) on energised¹⁾ runs
- Modular tap-off unit configuration

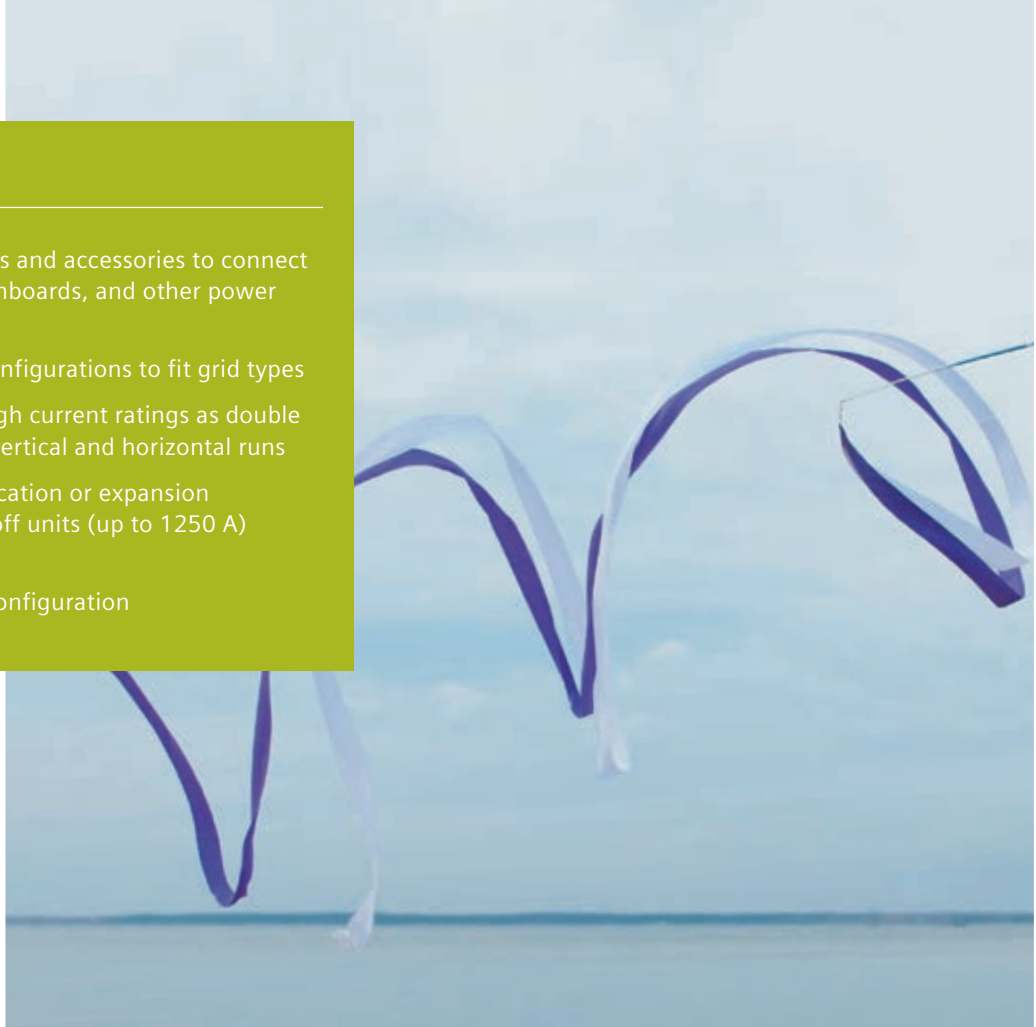

Flexibility in planning and operation.

Design your safe and sustainable solution

In the planning phase, the component portfolio of the LI system allows you to design your power supply system flexibly. The LI system offers a range of conductor configurations to fit any grid. Among others, tap-off units can be equipped with circuit breakers or fuse-type protection and switching devices.

Manifold junction units as well as the compact design of the system enable busbar runs to be adapted to complex infrastructures, or easily modified.

When new production lines might, for example, require new tap-off units for the machines and workplaces, the modular design and simple assembly of the LI system makes it possible to convert the workshop within a short space of time. Such quick and easy modifications are additionally supported by plug-on/-off tap-off units (up to 1250 A) connectable on energised busbar trunking systems¹⁾.

Flexibility is also provided for connection to the transformer with various compatible accessories.

1) In accordance with EN 50110-1 (VDE 0105-1); please always observe national regulations/standards

Reliable in operation.

Secure your system availability

Economic targets go hand in hand with high operational reliability. Thanks to the compact sandwich design, the LI system allows power transmission with a low voltage drop. Furthermore, the LI system can run at full load at high ambient temperatures¹⁾ without derating.

The LI system also supports you through robust and fail-safe hook and bolt connections with shear-off nuts to ensure high reliability for a long life span.

The high short-circuit rating and operational voltage of the LI system ensures a high power supply reliability for your infrastructure.

Your benefit

- High operational voltage ($U_e = 1000 \text{ V}$)
- High short-circuit rating
- Full load at high ambient temperatures
- Long busbar runs with low voltage drop due to sandwich design
- Hook and bolt connection with shear-off nut for optimised connection of the busbar trunking units

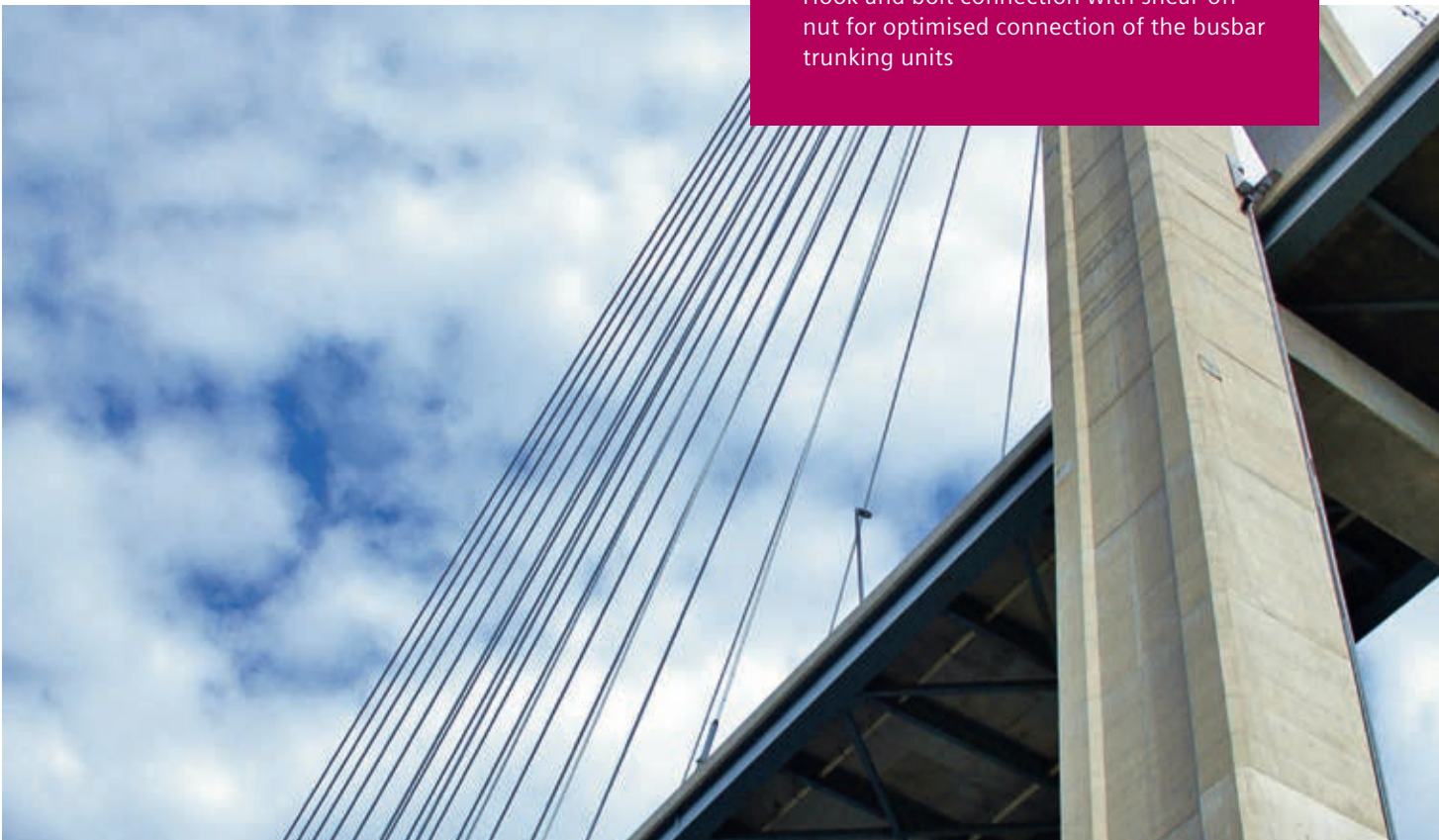

1) System-specific sizes of the LI System can run at full load up to 40 °C for 24-h-average

SIVACON 8PS – LI system

A compact system for safe and efficient power supply

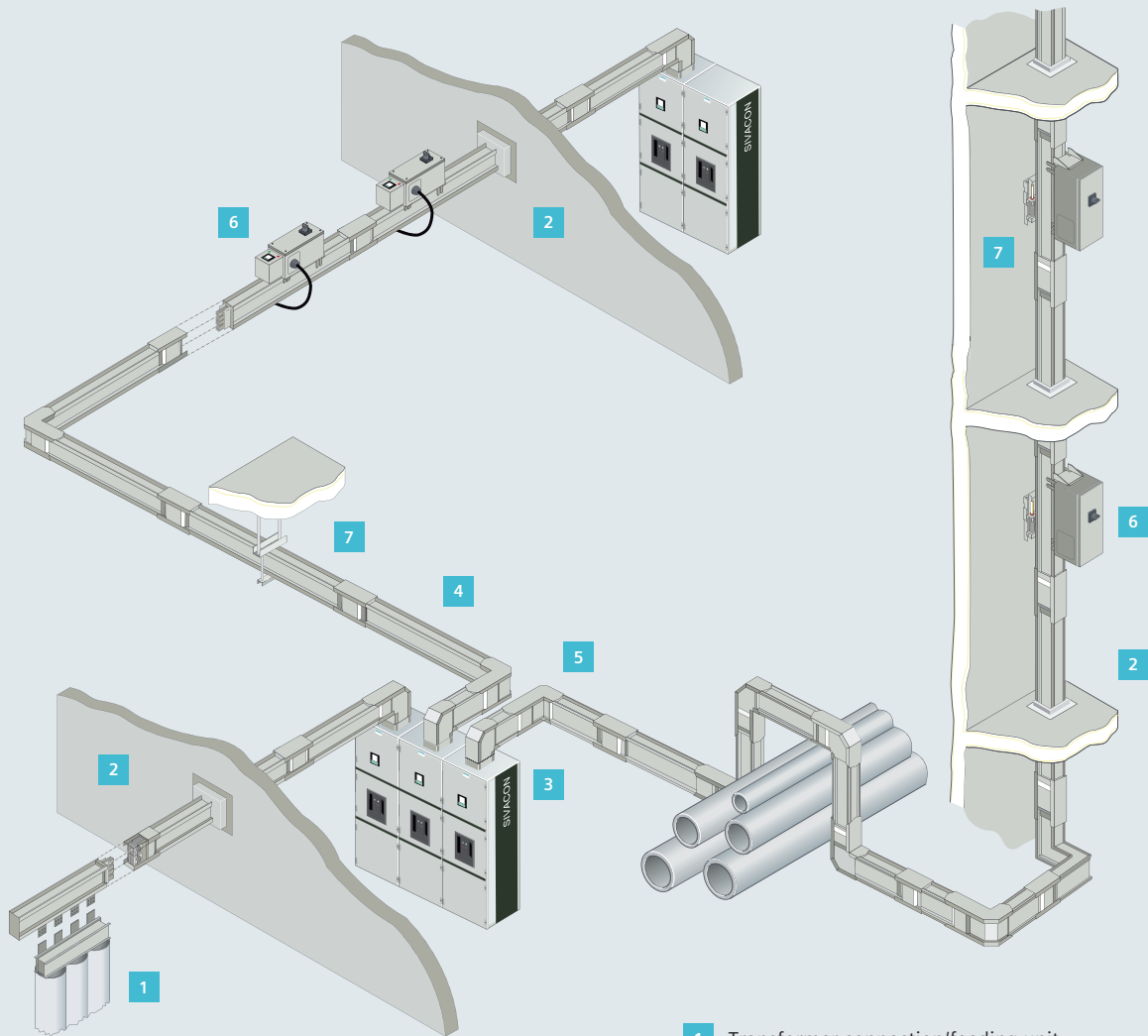

- 1 Transformer connection/feeding unit
- 2 Fire barrier
- 3 Connection/feeding unit to SIVACON S8
- 4 Straight trunking unit
- 5 Junction unit
- 6 Tap-off unit
- 7 Accessories for mounting

Body sizes

Compact dimensions save space and make installation easier

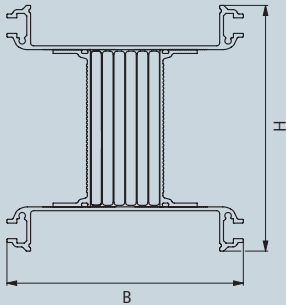

Single body

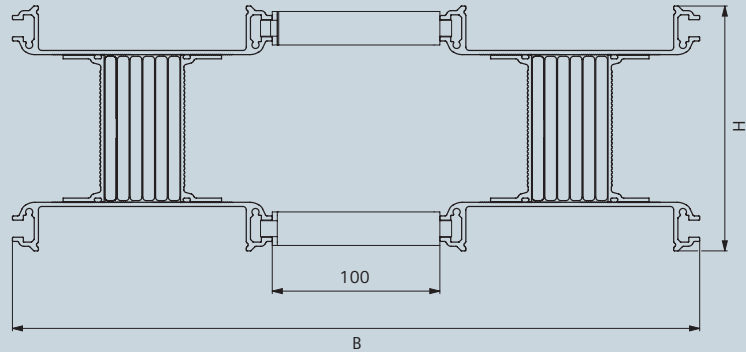

Double body

Body sizes

Various sizes are available depending on rated current and conductor material.

The number of aluminium or copper bars is determined by the conductor configuration required:

- Single bodies have one housing with 3 to 6 bars
- Double bodies have two housings with 6 to 12 bars

Please refer to content on page 14.

Material	Single body				Double body			
	Ampere ratings (A)	System	H (mm)	W (mm)	Ampere ratings (A)	System	H (mm)	W (mm)
Al	800	LIA0800	111	155				
Al	1000	LIA1000	132	155				
Al	1250	LIA1250	146	155				
Al	1600	LIA1600	182	155	3200	LIA3200	182	410
Al	2000	LIA2000	230	155	4000	LIA4000	230	410
Al	2500	LIA2500	297	155	5000	LIA5000	297	410
Cu	1000	LIC1000	111	155				
Cu	1250	LIC1250	117	155				
Cu	1600	LIC1600	146	155				
Cu	2000	LIC2000	174	155	4000	LIC4000	174	410
Cu	2500	LIC2500	213	155	5000	LIC5000	213	410
Cu	3200	LIC3200	280	155	6300	LIC6300	280	410

Conductor configuration

Wide range of configurations available to fit different requirements

Conductor configuration

The LI busbar trunking system offers different conductor configurations with PE, neutral conductor and Clean Earth version (see table).

For example, when neutral conductor overload has to be avoided due to electronic loads subject to harmonics, or to prevent interference potentials in the busbar housing impairing the operating capability of loads, the configuration with double neutral provides a reliable power supply.

Conductor configuration																						
①	②	③	④	①	②	③	④	⑤	①	②	③	④	⑤	⑥	①	②	③	④	⑤	⑥	⑦	
L1	L2	L3	PE _{hsg.}	PEN _{bar + hsg.}	L1	L2	L3	PE _{hsg.}	N	L1	L2	L3	PE _{100% bar + hsg.}	PE _{hsg.}	N	N	L1	L2	L3	CPE	PE _{hsg.}	
				①	②	③	④	⑤	①	②	③	④	⑤	⑥								
				N	L1	L2	L3	PE _{hsg.}	N	N	L1	L2	L3	PE _{hsg.}								
									①	②	③	④	⑤	⑥								
									N	L1	L2	L3	CPE	PE _{hsg.}								



Power transmission

Safe, flexible, and efficient solution

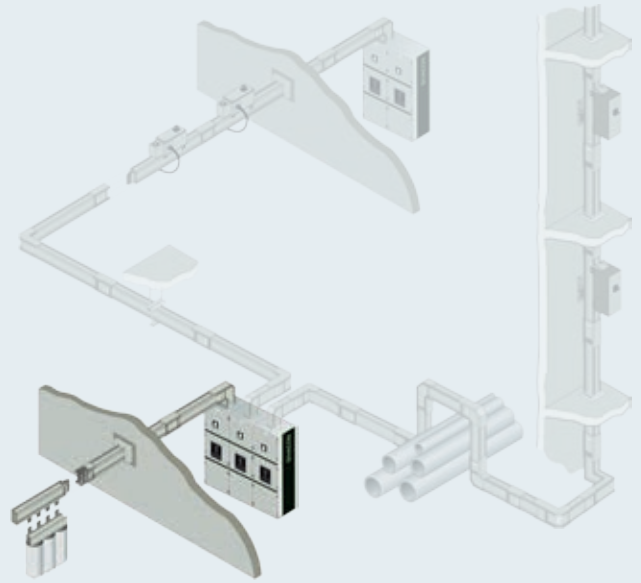
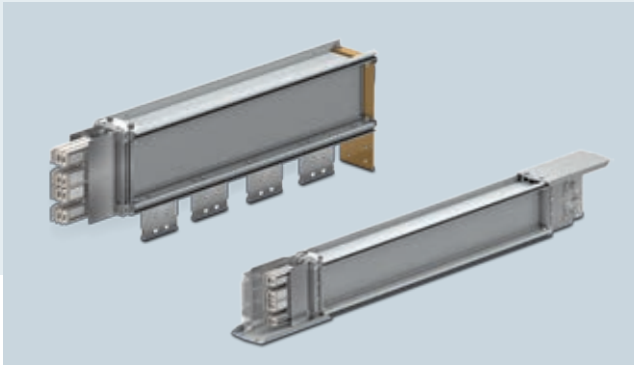

Transformer feeding unit and straight trunking unit

The LI system enables flexible and reliable power transmission up to 6300 A between transformers and low-voltage power distribution boards.

Various transformer feeding units, trunking units, as well as junction units allow a high level of flexibility in planning so as to meet the requirements of the specific application.

Flexible connection

The LI system offers various transformer feeding units to fit the variety of transformers available on the market with different rated currents, phase sequences, and phase distances. Up to 6300 A, the LI system offers transformer feeding units with a lateral busbar connection or with a busbar connection from the top. Universal feeding units can also be used for connection to distribution boards.

Reliable and flexible busbar runs

The LI system transmits large amounts of power over large distances with low voltage drop thanks to its sandwich design. Junction units like knees and elbows for changing directions into vertical and horizontal run positions serve perfectly to various building structures. Straight trunking units and junction units fulfil the degree of protection IP66 for trunking sections used for mere power transmission.

Your benefit

- Flexible planning thanks to various feeding units and junction units
- Efficient power transmission with low voltage drop over long distances thanks to compact sandwich design
- Safe power transmission with degree of protection up to IP66 as well as design verified connections to SIVACON S8 switchboards

Junction units

Standard elbow

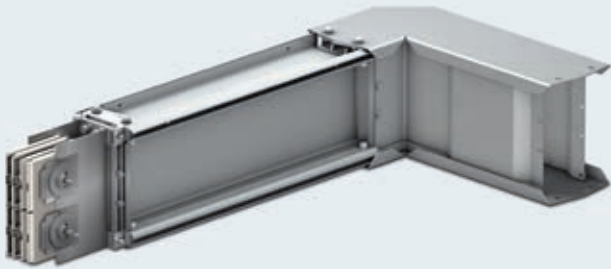

Standard knee

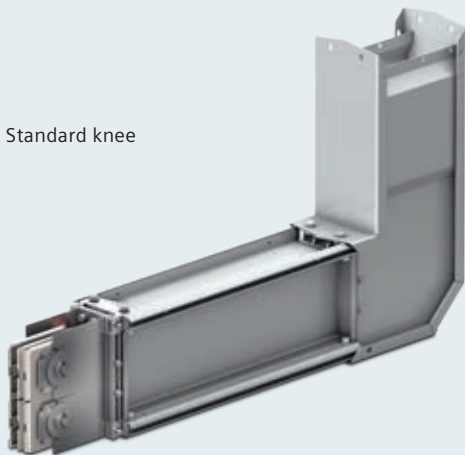

Furthermore, various elbows and knees are available with either standard or customised dimensions and angles to meet the exact structure of your building, however complex.

Safe and reliable connection between LI system and SIVACON S8 cubicle

As an integrated solution, the LI system offers a design verified connection to the SIVACON S8 switchboard for rated currents up to 6300 A. Flexible connections to the power distribution board can be made from above as well as from below for a safe, reliable, and efficient power supply.

Degrees of protection for safe power transmission

The LI system offers power runs with degree of protection IP66 for safe and reliable operation even in harsh industrial environments, or environments with high air humidity.

Power distribution

Safe, flexible, and future-proof solution

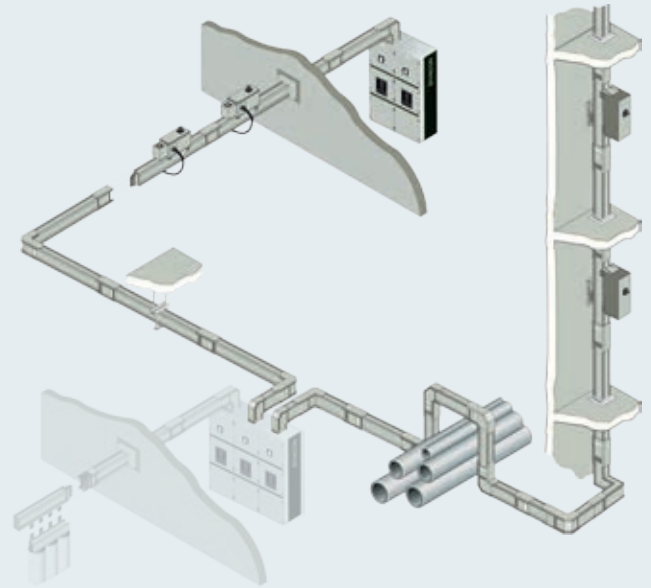
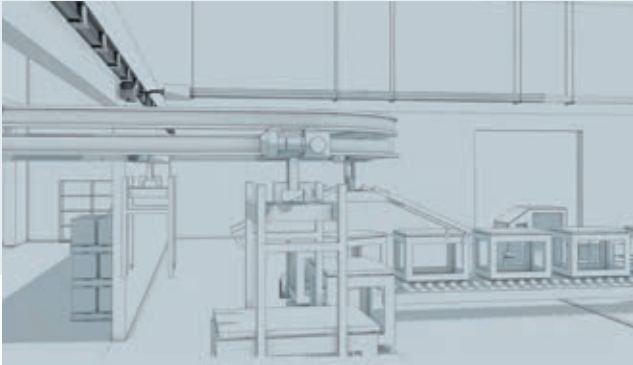

Power distribution is the main application of busbar trunking systems. The advantage of such systems over cable installations is a high level of flexibility allowing easy modifications in the future.

The LI system is the right solution where power distribution has to be flexibly implemented with horizontal and vertical busbar runs. Furthermore, its modular tap-off units allow to suit various applications. For easy integration into an energy management system, measuring devices can be built into tap-off units for a future-proof solution.

Modular tap-off units

Busbar trunking systems provide flexible power distribution via plug-on/-off tap-off units along the entire busbar run. If there are changes of location or modifications of the load, the power supply can be easily adapted – without downtime.

Power can be tapped at any given point by simply positioning a tap-off unit at the required location on the busbar. Tap-off units can be mounted on one or both sides of straight trunking units.

Your benefit

- Flexible planning thanks to various tap-off units
- Safe power distribution thanks to design verified system
- Flexible power distribution thanks to easy modification
- Future-proof power distribution thanks to integration in energy management solutions

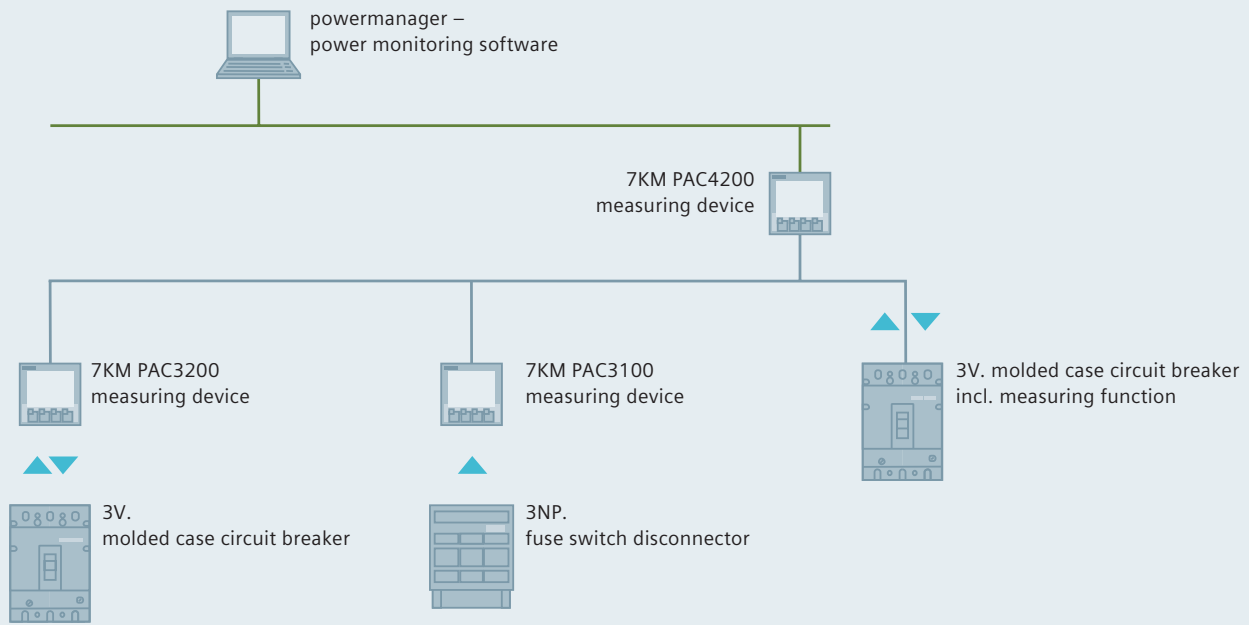

Example for power monitoring

The result is a flexible distribution system for decentralised power supply to a particular section of grid.

Tap-off units are available from 50 A to 1250 A for load connections. They can be equipped with fuse switch disconnectors, switch disconnectors with fuses, fuse bases¹⁾ (LV HRC), or circuit breakers.

Tap-off units with fuse-type protection and switching devices are available up to 630 A, with circuit breakers up to 1250 A.

The tap-off units can be used in a wide range of grid types. For conductor configurations with 200 % N, tap-off units offer a double N connector as well as Clean Earth with a separate PE conductor insulated to the housing.

Rugged tap-off unit housings ensure IP55 protection irrespective of the mounting position. The rated operational voltage (U_e) is 400 V.

Future-proof system

When energy data for transparent power flows or remote switching and monitoring are required, the LI system offers integrated and communication-capable switching and measuring devices as well as components for optimum energy management (including communication capabilities for Modbus TCP, PROFIBUS, and PROFINET).

1) Version with LV HRC fuse base cannot be plugged on energised LI runs

Modular tap-off units

Cable entry to tap-off units

Cable entry is possible from the side or from the end. The basic tap-off units are designed with blanking plates which are equipped with cable glands locally. As an accessory, cable entry plates with fitted cable grommets are available for multi-core and single-core cables.

Safe in installation and operation

- Guided plugging with a plug-on/off facility on the tap-off point avoids incorrect fitting, ensures IP2X and IPXXB during the plugging process, and indicates unambiguously if the tap-off unit is disconnected or connected
- Leading PE contact ensures a protective conductor connection during assembly or disassembly
- Isolation of tap-off units during removal is assured by a compulsory sequence of operations
- Quick and easy modifications or expansions with plug-on/off tap-off units (up to 1250 A) on energised²⁾ busbars
- Contact device section in the front of the tap-off unit is finger-proof

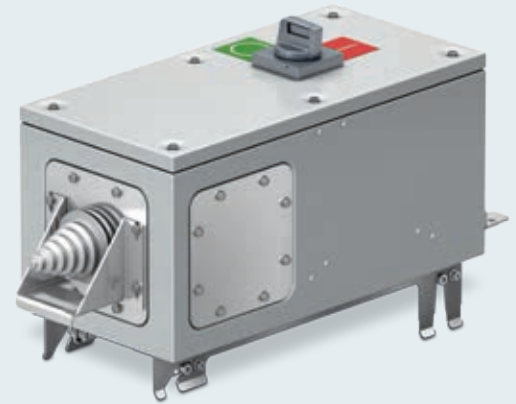

Tap-off unit with circuit breaker

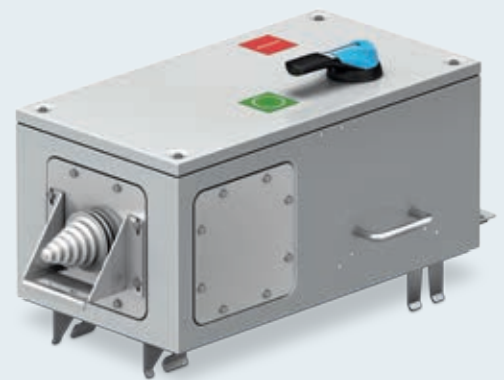

Tap-off unit with fuse-type switching device

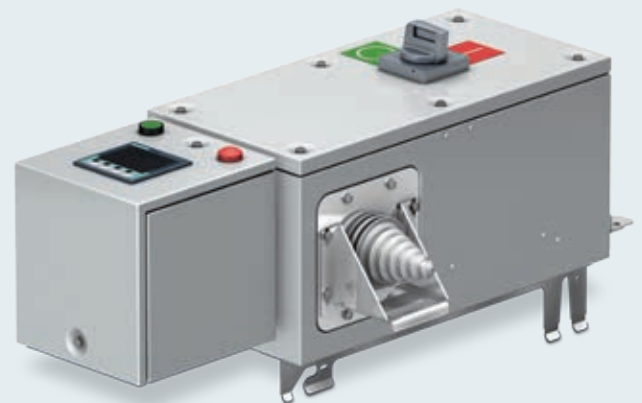

Tap-off unit with measuring device

²⁾ In accordance with EN 50110-1 (VDE 0105-1); please always observe national regulations/standards

Hook and bolt connections

Safe and reliable installation

Step 1

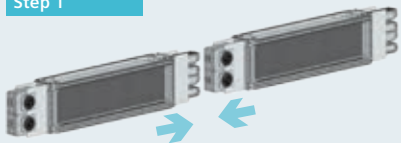

Align the trunking ends with hook and bolt. Join and connect the busbar elements.

Step 2

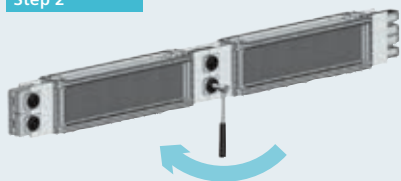

Tighten the self-torque bolt until the outer head of the nut shears off. This indicates a correct torque level of 50 Nm.

Step 3

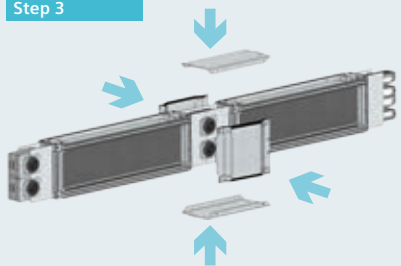

Install side covers followed by top and bottom covers. Then, fasten bolts.

Step 4



The final hook and bolt connection fulfils the degree of protection IP66.

Trunking units are assembled easily and safely using hook and bolt connections with shear-off nuts – for an efficient and reliable installation.

Busbar connection via hook and bolt connection

The trunking units are interconnected through a hook-and-bolt technology. For this purpose, a hook is integrated on one side of each trunking unit, and a bolt on the other side. In this way, there is only one transition for each electrical conductor, ensuring a large-surface contact for an outstanding connection quality and durable electrical contact at the same time. The mechanical connection of the electrical conductors is established by coupling the hook and the bolt, and subsequent tightening of the bolt with a simple standard key. When the necessary clamping pressure is reached, the outer nut head is automatically sheared off. This gives simple and instant confirmation of correct assembly.

After tightening the hook and bolt connection, the clamping point is covered with a connection flange. The side protection cover can only be fitted once the outer nut head has sheared off (see figure, step 2).

After fitting of the protection covers the hook and bolt connection fulfils the high degree of protection IP66.

Your benefit

- Safe trunking unit connection with IP66
- High connection quality with low contact resistance
- Higher rigidity of the system thanks to hook and bolt connection



Safe and reliable hook and bolt connections

Technical data

Standards and prescriptions	IEC 61439-1/-6, EN 61439-1/-6	
Ambient air temperature (min./max./24-h mean)	°C	-5/+40/+35
Degree of protection	IP55; IP66 ¹⁾	
Mounting positions	Horizontal edgewise, horizontal flat, vertical	
Busbar surface treatment	At the current transitions: LI-A nickel-coated and tin-plated, LI-C tin-plated	
Insulation	Mylar®	
Degree of protection against mechanical impacts	IK08	
Trunking unit material	Aluminium, powder-coated	
Tap-off unit material	Steel sheet, powder-coated	
Colour of trunking unit, tap-off unit	RAL 7035 (light gray)	
Rated insulation voltage in acc. with IEC 61439-1	V AC	1000
Rated operational voltage (power transmission) for overvoltage category III/3	V AC	1000
Rated operational voltage (power distribution with tap-off units) for overvoltage category III/3	V AC	690
Frequency	Hz	50/60 ²⁾

1) IP66 for mere power transmission runs without tap-offs

2) In accordance with IEC 61439, a reduction to 95 % has to be considered for currents > 800 A at a frequency of 60 Hz

LI-A											
Ampere ratings ³⁾	A	800	1000	1250	1600	2000	2500	3200	4000	5000	
Conductor material	Aluminium										
Short-circuit rating											
Rated short-time withstand current (1s)	I_{cw}	kA	35	50	60	65	80	100	120	150	150
Rated peak withstand current	I_{pk}	kA	74	105	132	143	176	220	264	330	330

LI-C											
Ampere ratings ³⁾	A	1000	1250	1600	2000	2500	3200	4000	5000 ⁴⁾	6300	
Conductor material	Copper										
Short-circuit rating											
Rated short-time withstand current (1s)	I_{cw}	kA	43	60	65	80	100	100 ⁵⁾	150	150	150
Rated peak withstand current	I_{pk}	kA	90	132	143	176	220	220 ⁵⁾	330	330	330

3) Rated currents I_{nA} according to current values without derating at higher ambient temperatures up to 40 °C for 24-h-average possible for system-specific sizes (on request)

4) Rated current I_{nA} is 4890 A at an ambient temperature of 35 °C

5) With PE bar (100%), $I_{cw} = 120$ kA, $I_{pk} = 264$ kA

Tap-off units with circuit breaker¹⁾

Ampere ratings	A	50 – 160	200 – 250	315 – 400	500 – 630	800 – 1250
Rated conditional short-circuit current (I_{cc}) with switching capacity N	kA	55	55	55	55	55
Rated conditional short-circuit current (I_{cc}) with switching capacity H	kA	70	70	70	70	70
Rated conditional short-circuit current (I_{cc}) with switching capacity L	kA	100	100	100	100	100

Tap-off units with fuse-type protection/switching devices²⁾

Ampere ratings	A	160	250	400	630
Short-circuit rating ³⁾ with fuse protection type 3NP.. with fuse protection (I_{ct})	kA	100	100	100	100
Short-circuit rating ³⁾ with fuse protection type FSF.. with fuse protection (I_{ct})	kA	100	100	100	100
Short-circuit rating ³⁾ with fuse protection type NH.. with fuse protection (I_{ct})	kA	120	120	120	120

1) Valid for $U_e = 400$ V

2) Tested with Siemens LV HRC fuses, $U = 690$ V on request

3) Depending on fuse type and manufacturer

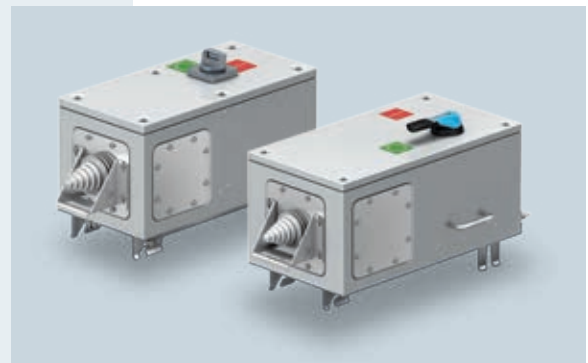
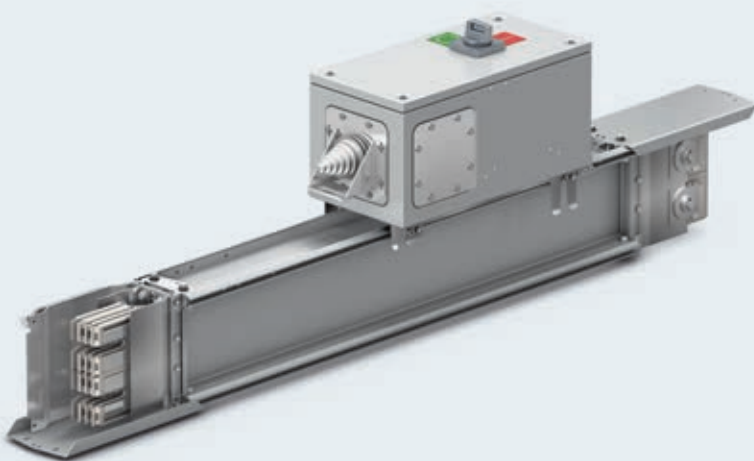

Support

Optimise your time with Siemens as a competent partner at your side



SIVACON 8PS busbar trunking systems on the Internet

Our website offers you a broad range of information as well as helpful tools for the SIVACON 8PS busbar trunking systems. Just click and have a look!

[siemens.com/busbar](https://www.siemens.com/busbar)

Comfortable planning: With the SIMARIS tools

Planning electric power distribution for industrial plants, infrastructure, and buildings is becoming more and more complex. To help you, as an electrical planning engineer, to work faster and better under existing conditions, the innovative SIMARIS software tools effectively support your planning process.

SIMARIS design

Dimensioning electric grids, and automatically selecting components

SIMARIS project

Determining space requirements and budget for power distribution systems

SIMARIS sketch

Designing routing diagrams in 3D for the BD01, BD2, LD, LI, and LR busbar trunking systems

[siemens.com/simaris](https://www.siemens.com/simaris)

Efficiency from planning to maintenance by using BIM data

Within the scope of digitalisation, Building Information Modeling (BIM) offers great benefits already in the planning process. Easy exchange of all relevant building data from planning to facility management ensures quality and saves both time and money. For this reason, BIM also plays an increasingly important part in electrical planning.

[siemens.com/bim-eplanning](https://www.siemens.com/bim-eplanning)

Technical documentation on the Internet

You will find an overview of the latest technical documentation available for SIVACON 8PS busbar trunking systems on our website (updated daily) at

[siemens.com/lowvoltage/product-support](https://www.siemens.com/lowvoltage/product-support)

Tender specification texts

We offer a comprehensive range of specification texts to support you at

[siemens.com/specifications](https://www.siemens.com/specifications)

Build on a sound basis

Our courses offer you solid foundations for your business success.

Expert lecturers provide you with the necessary theoretical and practical information relating to our SIVACON 8PS busbar trunking systems.

[siemens.com/lowvoltage/training](https://www.siemens.com/lowvoltage/training)

Reliable local support

Our local experts are there for you around the world, helping you to develop solutions for your energy supply, and providing you with specific expertise on project management and financial services. Important aspects of safety, logistics, and environmental protection are considered.

Technical experts from TIP Consultant Support offer support, especially for planning and conception of electrical power distribution systems.

[siemens.com/tip-cs](https://www.siemens.com/tip-cs)

